



COOPI – COOPERAZIONE INTERNAZIONALE

Tender dossier

Contract title Energy technologies for the the ECHO SET4food pilot project in Lebanon

Location – Batroun and Koura District, North Lebanon, Lebanon

Publication reference

SET4food/Lebanon/01

Program

Sustainable energy technologies for food utilization (SET4food)

Description of the contract

In the framework of the SET4food program, COOPI – COOPERAZIONE INTERNAZIONALE will implement a pilot project in Koura and Batroun districts, North Lebanon, whose main goal is testing a number of energy technologies for food preparation and storage in already identified informal settlements of Syrian refugees. Given that, the object of the contract is represented by the above mentioned energy technologies, whose description is included in the tender dossier (for any further detail, please refer to the paragraph 1.1 “tasks to be executed”).

Period of execution

2 weeks after the signature of the contract (Wednesday 18 of March 2015)

Deadline for submission of tenders

- Time: 10:00 local time.

- Date: 02/03/2015

Please note: Costs incurred by the tenderer in preparing and submitting the tender proposals will not be reimbursed.

Tender dossier Summary

A. <i>Instructions to tenderers</i>	4
1. <i>Tasks to be executed</i>	4
2. <i>Timetable</i>	4
3. <i>Participation</i>	4
4. <i>Currency</i>	5
5. <i>Items requested, quantities and lots</i>	5
6. <i>Period of validity</i>	5
7. <i>Language of offers</i>	5
8. <i>Submission of tenders</i>	6
9. <i>Content of tenders</i>	6
10. <i>Pricing</i>	7
11. <i>Additional information before the deadline for the submission of tenders</i>	7
12. <i>Alteration or Withdrawal of tenders</i>	7
13. <i>Opening of tenders</i>	8
14. <i>Evaluation of tenders</i>	8
15. <i>Performance Guarantee</i>	9
16. <i>Signature of the Contract</i>	9
17. <i>Ethic and Exclusion Clauses</i>	10
18. <i>Cancellation of the tender procedures</i>	11
B. <i>ANNEXES</i>	13
<i>Annex I - Application Form</i>	14
<i>Annex II - Declarations from the Supplier</i>	21
<i>Annex III - Model of Financial/Technical Offer</i>	25
<i>Annex IV – Work Plan for Performing the Task</i>	27
<i>Annex V – Draft Contract</i>	29

A. INSTRUCTIONS TO TENDERERS

PUBLICATION REF: SET4food/Lebanon/01

1. *Tasks to be executed*

1.1 COOPI – COOPERAZIONE INTERNAZIONALE has received a grant from the European Commission Humanitarian Office (ECHO) for the implementation of the operation entitled “Sustainable energy technologies for food utilization (SET4food)” and intends to apply a portion of that grant to payments under this contract. No party other than COOPI – COOPERAZIONE INTERNAZIONALE shall derive any rights from the grant or have any claim to its proceeds. Under no circumstances or for no reason whatsoever will the donor entertain any request for indemnity or payment directly submitted by the humanitarian organisation’s contractors

1.2 The subject of the contract is the delivery of the following supplies or installation of the following systems by the Contractor in Syrian refugee informal settlements in Koura and Batroun districts:

- **LOT 1:** Supply and delivery of twenty-five (25) solar-home-systems in DC. Each system will provide lighting and power.

Each system has to be composed as follows:

- 1 PV panel, 30 W @ 12 V;
- 1 battery 20 Ah @ 12 V;
- 1 Charge controller suitable for the system (at least 3 A);
- 2 LED inside lights, 5W each, for indoor use;
- 2 LED security lights, 5W each, for outdoor use;
- 1 USB port;
- An adequate wiring;
- Other items (e.g. lamp holders) or fittings required to install the system and to make it operational.

The system can be either a solar kit or self-assembled. In any case, the system has to be easy and safe to connect and disconnect also for non-technical people.

The Contractor is in charge of the shipping of all the materials to COOPI – COOPERAZIONE INTERNAZIONALE office in Kfaraabida. All the costs have to be incorporated in the bid, including any taxation. The supply will be considered effectively delivered only when received by a COOPI – COOPERAZIONE INTERNAZIONALE representative, based on the release of a written certificate of delivery.

All the materials have to be covered by a warranty whose minimum duration is 10 months after provisional acceptance.

When the Contractor is selected, COOPI – COOPERAZIONE INTERNAZIONALE may request the supply and delivery of other solar-home-systems with the same characteristics above-mentioned, up to a maximum of forty (40). The price of such an extra-supply will be directly negotiated by COOPI – COOPERAZIONE INTERNAZIONALE with the Contractor.

- **LOT 2:** Supply and installation of thirteen (13) self-assembled solar-home-systems in DC. Each system will provide lighting to a household and power to a thermoelectric refrigerator.

Each system has to be composed as follows:

- 1 PV panel, 200 W @ 12 V;
- 1 battery 80 Ah @ 12 V;
- 1 Charge controller suitable for the system (at least 20 A);
- 1 Thermoelectric fridge with capacity between 20 and 40 l, in DC, 12 V, maximum power absorption 50 W, maximum power consumption in standard testing conditions (STC) 300 Wh/day;
- 2 LED inside lights, 5W each, for indoor use;
- 2 LED security lights, 5W each, for outdoor use;
- 1 fuse DC (50 A);
- An adequate wiring and switchers for the LEDs;
- Other items (e.g. lamp holders) or fittings required to install the system and to make it operational.

The system has to be easy to connect and disconnect.

The Contractor is in charge of the shipping of all the materials to Kfarsaroun, Koura District, and the installation in the 13 households selected. All the costs have to be incorporated in the bid, including any taxation. The system has to be installed in compliance with local national regulation, and to ensure the safety of both the workers involved, and the users of the system. The system will be considered effectively installed only after a visit by a COOPI – COOPERAZIONE INTERNAZIONALE representative, based on the release of a written certificate of completion.

All the materials have to be covered by a warranty whose minimum duration is 10 months after provisional acceptance.

- **LOT 3:** Supply and installation of one (1) solar system in the settlement close to Hollow blocks factory, Chekka, Batroun District. This system will provide lighting to 20 households and power to 5 refrigerators.

The system has to be composed as follows:

- PV panel for a total power of 2.5 kW @ 24 V (e.g. 8 strings of 300 W @ 24 V);
- Batteries 500 Ah @ 24 V in series;
- A suitable number of charge controllers will be required, in order to manage a DC current up to 100 A;
- 1 inverter suitable for the system (2 kW);
- 40 LED inside lights, 5W each, for indoor use (2 per each household);
- 40 LED security lights, 5W each, for outdoor use (2 per each household);
- 5 extra sockets (where refrigerators are located);
- 5 compressor refrigerators, each one with capacity between 100 and 250 l, in AC, 220-240 V, maximum power absorption 100 W, maximum power consumption in standard testing conditions (STC) 300 Wh/day;
- An adequate wiring and switchers for the loads;
- 1 fuse DC (200 A);
- 1 isolator switch;
- Other devices, items (e.g. lamp holders, frames for PV panel installation) or fittings required to install the system and to make it operational.
- 1 Power Meters AC (Single Phase DIN-rail Type Kilowatt Hour kWh Meter 220V);

- 1 Miniature circuit breaker (MCB) with protected neutral LN, C, 16A, 6 kA

The tenderer is invited to survey the site, in order to propose the most suitable installation scheme. However any cost related to preliminary activities like this will not be covered by COOPI, no matter the tenderer will be contracted or will not.

The Contractor is in charge of the shipping of all the materials to the settlement close to Hollow blocks factory, Chekka, Batroun District, and of the installation of the system, including lights inside all the 20 households selected. All the wirings, fittings and any other device or accessory required for a complete and effective installation of the system have to be provided by the Contractor, as well as any civil work, if required. The system has to be installed in compliance with local national regulation, and to ensure the safety of both the workers involved, and the users of the system.

All the costs have to be incorporated in the bid, including any taxation. The system will be considered effectively installed only after a visit by a COOPI – COOPERAZIONE INTERNAZIONALE representative, based on the release of a written certificate of completion.

All the materials have to be covered by a warranty whose minimum duration is 10 months after provisional acceptance.

- **LOT 4:** Supply and installation of one (1) hybrid (solar and wind) system in Waha Center, Deddeh, Koura district. This system will provide power to 8 refrigerators to be installed in the Waha Center.

The system has to be composed as follows (on possible configuration depicted in the picture below):

- 1 horizontal-axis wind turbine, 2.5 kW
- One system with solar PV panels, polycrystalline technology, total power installed 6 kW;
- Batteries (25 kWh);
- 1 or more charge controllers suitable for the PV system;
- 1 or more charge controllers suitable for the WIND system
 - As an option a unique charge controller (able to manage both PV and WIND generator) may be adopted
- 1 inverter suitable for the system (5 kW);
- 8 refrigerators, each one with 8 independent lockable compartments, a global capacity between 400 and 700 l, maximum absorption 350W, maximum power consumption in standard testing conditions (STC) 3600 Wh/day. All the refrigerators have to be equipped with eutectic plates for static cooling or another device with comparable performance;
- 2 Power Meters AC (Single Phase DIN-rail Type Kilowatt Hour kWh Meter 220V);
- 1 DC Energy Meter suitable for each DC line.
- 1 Miniature circuit breaker (MCB) with protected neutral LN, C, 16A, 6 kA
- 3 Miniature circuit breaker (MCB) with protected neutral LN, C, 10A, 6 kA
- 1 suitable fuse for each DC line
- 1 isolator switch for each DC line + 1 after the output of the Battery bank
- 1 Power outlet 16 A
- 3 Power outlet 10 A
- 1 switchboard (DIN-rail) devoted to integrate all the listed component

- An adequate wiring and switchers for the loads;
Other items or fittings required for a full installation of the system and to make it operational

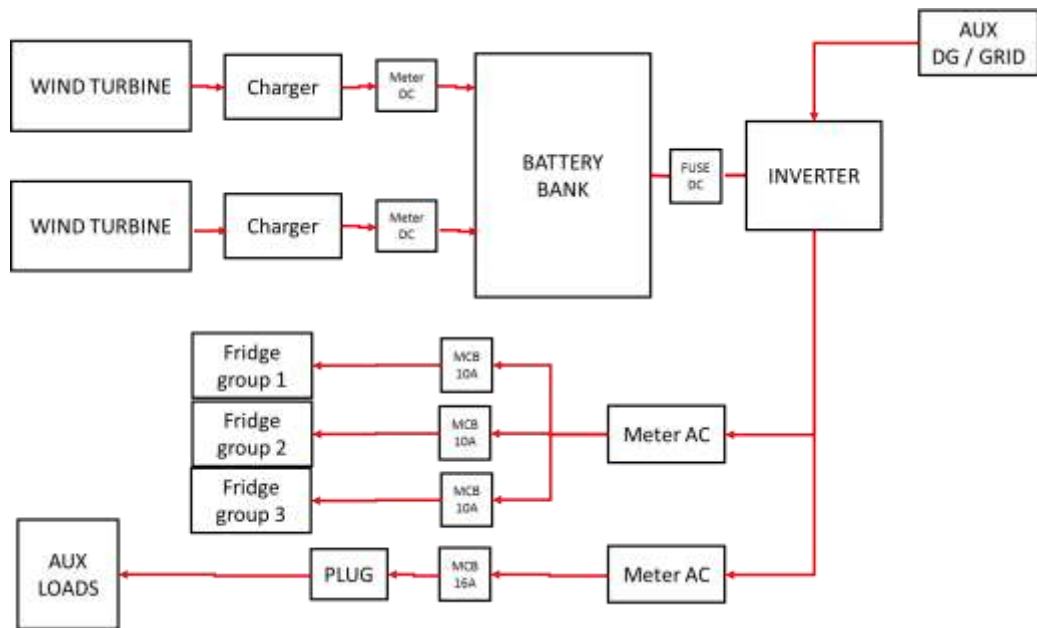

Example of the possible configuration

The tenderer is invited to survey the site, in order to propose the most suitable installation scheme. However any cost related to preliminary activities like this will not be covered by COOPI, no matter the tenderer will be contracted or will not.

Solar panels and wind turbine will be installed on the roof of the Waha Center. Batteries, charge controllers, inverter and all the devices will be properly accommodated to ensure their operation and safety, as well as user's safety.

Refrigerators will be installed inside the Waha Center, 2 per floor, as it will be indicated by COOPI – COOPERAZIONE INTERNAZIONALE.

The Contractor is in charge of the shipping of all the materials to Waha Center, Deddeh, Koura district, and of the installation of the system. . All the wirings, fittings and any other device, item or accessory required for a complete and effective installation of the system have to be provided by the Contractor, as well as any civil work, if required. The system has to be installed in compliance with local national regulation, and to ensure the safety of both the workers involved, and the users of the system.

All the costs have to be incorporated in the bid, including any taxation. The system will be considered effectively installed only after a visit by a COOPI – COOPERAZIONE INTERNAZIONALE representative, based on the release of a written certificate of completion.

All the materials have to be covered by a warranty whose minimum duration is 10 months after provisional acceptance.

- **LOT 5:** Supply and delivery of twenty-five (25) vacuum sealer systems for packaging for food preservation. Each system has to be composed of 1 vacuum sealer hand-pump (not electrical) and 30 three quart-size vacuum freezer bags.

During the evaluation of tenders, COOPI – COOPERAZIONE INTERNAZIONALE may request to check a sample of the supply proposed in Kfarabida or in any other COOPI

– COOPERAZIONE INTERNAZIONALE branch office. If this sample is not available, the Contractor will be automatically excluded.

The Contractor is in charge of the shipping of all the materials to COOPI – COOPERAZIONE INTERNAZIONALE office in KFARAABIDA. All costs have to be incorporated in the bid, including any taxation. The supply will be considered effectively delivered only when received by a COOPI – COOPERAZIONE INTERNAZIONALE representative, based on the release of a written certificate of delivery.

All the materials have to be covered by a warranty whose minimum duration is 10 months after provisional acceptance.

When the Contractor is selected, COOPI – COOPERAZIONE INTERNAZIONALE may request the supply and delivery of other outdoor lighting systems with the same characteristics above-mentioned, up to a maximum of forty (40). The price of such an extra-supply will be directly negotiated by COOPI – COOPERAZIONE INTERNAZIONALE with the Contractor.

- **LOT 6:** Production and delivery of twenty-five (25) ELSA cookstoves. Each cookstove has to be produced according to the official blueprint and assembled according to the construction manual. Both the blueprint (drawings) and the manual are attached or can be downloaded for free by <http://www.blucomb.com/product/elsa-blueprint-pdf/>. The model with scale 1:2.24 has to be considered. The cookstove has to be produced in stainless steel, grade 316 or 306, thickness 0.5 - 0.6 mm.

The Contractor is in charge of the shipping of all the materials to COOPI – COOPERAZIONE INTERNAZIONALE office in KFARAABIDA. All costs have to be incorporated in the bid, including any taxation. The supply will be considered effectively delivered only when received by a COOPI – COOPERAZIONE INTERNAZIONALE representative, based on the release of a written certificate of delivery.

All the materials have to be covered by a warranty whose minimum duration is 10 months after provisional acceptance.

- **LOT 7:** Production and delivery of thirteen (13) pot skirts for moveable gas burner. Each pot skirt has to be produced according to the drawings attached (please, consider a diameter of the pot of 40 cm). However the pot skirt has to be appropriate for gas burners most commonly used by Syrian refugees in Lebanon. The pot skirt has to be produced in stainless steel, grade 316 or 306, thickness 0.5 or 0.6 mm.

The Contractor is in charge of the shipping of all the materials to COOPI – COOPERAZIONE INTERNAZIONALE office in Kfaraabida. All costs have to be incorporated in the bid, including any taxation. The supply will be considered effectively delivered only when received by a COOPI – COOPERAZIONE INTERNAZIONALE representative, based on the release of a written certificate of delivery.

All the materials have to be covered by a warranty whose minimum duration is 10 months after provisional acceptance.

When the Contractor is selected, COOPI – COOPERAZIONE INTERNAZIONALE may request the supply and delivery of other pot skirts with the same characteristics above-mentioned, up to a maximum of twenty (20). The price of such an extra-supply will be directly negotiated by COOPI – COOPERAZIONE INTERNAZIONALE with the Contractor.

- **LOT 8:** Supply and delivery of sixty-seven (67) pressure cookers. Each pressure cooker will have a capacity of 6 liters, and will be equipped with a safety valve.

During the evaluation of tenders, COOPI – COOPERAZIONE INTERNAZIONALE may request to check a sample of the supply proposed in Kfaraabida or in any other COOPI – COOPERAZIONE INTERNAZIONALE branch office. If this sample is not available, the Contractor will be automatically excluded.

The Contractor is in charge of the shipping of all the materials to COOPI – COOPERAZIONE INTERNAZIONALE office in Kfaraabida. All costs have to be incorporated in the bid, including any taxation. The supply will be considered effectively delivered only when received by a COOPI – COOPERAZIONE INTERNAZIONALE representative, based on the release of a written certificate of delivery.

All the materials have to be covered by a warranty whose minimum duration is 10 months after provisional acceptance.

When the Contractor is selected, COOPI – COOPERAZIONE INTERNAZIONALE may request the supply and delivery of other pressure cookers with the same characteristics above-mentioned, up to a maximum of sixty-seven (67). The price of such an extra-supply will be directly negotiated by COOPI – COOPERAZIONE INTERNAZIONALE with the Contractor.

- **LOT 9:** Supply and delivery of thirteen (13) portable UV water purification devices. Each device has to be proven to be effective to remove at least 99% of microbiological contamination. It has to be equipped with a battery and charged by either an integrated solar panel, or a USB cable.

During the evaluation of tenders, COOPI – COOPERAZIONE INTERNAZIONALE may request to check a sample of the supply proposed in Kfaraabida or in any other COOPI – COOPERAZIONE INTERNAZIONALE branch office. If this sample is not available, the Contractor will be automatically excluded.

The Contractor is in charge of the shipping of all the materials to COOPI – COOPERAZIONE INTERNAZIONALE office in Kfaraabida. All costs have to be incorporated in the bid, including any taxation. The supply will be considered effectively delivered only when received by a COOPI – COOPERAZIONE INTERNAZIONALE representative, based on the release of a written certificate of delivery.

All the materials have to be covered by a warranty whose minimum duration is 10 months after provisional acceptance.

When the Contractor is selected, COOPI – COOPERAZIONE INTERNAZIONALE may request the supply and delivery of other water purification devices with the same characteristics above-mentioned, up to a maximum of twelve (12). The price of such an extra-supply will be directly negotiated by COOPI – COOPERAZIONE INTERNAZIONALE with the Contractor.

- **LOT 10:** Supply and delivery of thirteen (13) portable UV water purification devices. Each device has to be proven to be effective to remove at least 99% of microbiological contamination. It has to be equipped with a battery and charged by either an integrated solar panel, or a USB cable.

During the evaluation of tenders, COOPI – COOPERAZIONE INTERNAZIONALE may request to check a sample of the supply proposed in Kfaraabida or in any other COOPI – COOPERAZIONE INTERNAZIONALE branch office. If this sample is not available, the Contractor will be automatically excluded.

The Contractor is in charge of the shipping of all the materials to COOPI – COOPERAZIONE INTERNAZIONALE office in Kfaraabida. All costs have to be incorporated in the bid, including any taxation. The supply will be considered effectively delivered only when received by a COOPI – COOPERAZIONE INTERNAZIONALE representative, based on the release of a written certificate of delivery.

All the materials have to be covered by a warranty whose minimum duration is 10 months after provisional acceptance.

When the Contractor is selected, COOPI – COOPERAZIONE INTERNAZIONALE may request the supply and delivery of other water purification devices with the same characteristics above-mentioned, up to a maximum of twelve (12). The price of such an

extra-supply will be directly negotiated by COOPI – COOPERAZIONE INTERNAZIONALE with the Contractor.

1.3 The technical specifications of the supplies including quantities, models, samples, measurements, costs, etc. must be entered in the Model of financial/technical offer (Annex III of this tender dossier). In particular the following documents have to be attached:

- **Lot 1:** scheme of the system proposed; technical specifications of all the devices included;
- **Lot 2:** scheme of the system proposed; technical specifications of all the devices included;
- **Lot 3:** scheme of the system proposed; technical specifications of all the devices included;
- **Lot 4:** scheme of the system proposed; technical specifications of all the devices included;
- **Lot 5:** technical specifications of the model proposed;
- **Lot 8:** technical specifications of the model proposed;
- **Lot 9:** technical specifications of the model proposed;
- **Lot 10:** technical specifications of the model proposed.

2. *Timetable*

Deadline for submission of tenders	<u>02/03/2015</u>	12.00
Tender opening session	<u>04/03/2015</u>	12.00
Foreseen date for the signature of the contract	<u>06/03/2015</u>	-
Maximum deadline for delivery of the supplies or installation of the systems	<u>2 weeks after the signature of the contract</u>	

3. *Participation*

3.1. Participation in this tendering procedures is open on equal terms to all persons coming within the scope of the declarations annexed herein (Annex II) and to all such natural and legal persons.

3.2. These terms refer to all legal entities, companies or partnerships constituted under, and governed by, the civil, commercial or public law of their states and having their statutory office, central administration or principal place of business there. A legal entity, company or partnership having only its statutory office there must be engaged in an activity which has an effective and continuous link with the economy of the state concerned. Tenderers must provide evidence of their status.

3.3. These rules apply to:

- a) tenderers
- b) members of a consortium
- c) any subcontractors.

3.4. Candidate or tenderers must sign declarations regarding the compliance to ethical standards and the non-exclusion clauses (annex II).

3.5. To be eligible for participation in this tender procedure, tenderers must prove to the satisfaction of the Contracting Authority that they comply with the necessary legal, technical and financial requirements and have the wherewithal to carry out the contract effectively (see Annex I - Application form).

4. Currency

4.1. Tenders must be presented in USD.

5. Items requested, quantities and lots

The tenderer may submit a tender for all the lots. Each lot will form a separate contract and the quantities indicated for different lots will be indivisible. The tenderer must offer the whole of the quantity or quantities indicated for each lot. Under no circumstances will tenders for part of the quantities required be taken into consideration. If the tenderer is awarded more than one lot, a single contract may be concluded covering all those lots.

6. Period of validity

6.1. Tenderers shall be bound by their tenders for a period of 90 days from the deadline for the submission of tenders.

6.2. The successful tenderer will be bound by the tender for a further period of 60 days following receipt of the notification that the tenderer has been selected.

7. Language of offers

7.1. The offers, all correspondence and documents related to the tender exchanged by the tenderer and the Contracting Authority must be written in English.

8. Submission of tenders

8.1. Tenders must be received before the deadline specified in the letter of invitation to tender. They must include the Application form (Annex I of this tender dossier) and be sent to the following address:

COOPI – COOPERAZIONE INTERNAZIONALE Kfarabida Branch Office

Tenders must comply with the following conditions:

All tenders must be submitted in one original copy typewritten or hand written in ink. All tenders must be received at COOPI – COOPERAZIONE INTERNAZIONALE Kfarabida Branch Office before the deadline date and time (02/03/2015: 12.00) by registered letter with acknowledgement of receipt or hand-delivered against receipt signed by a tenderer representative.

8.2. All tenders, including annexes and all supporting documents, must be submitted in a sealed envelope bearing only:

- a) the above address;
- b) the reference code of this tender procedure;
- c) where applicable, the number of the lot(s) tendered for;
- d) the words “Not to be opened before the tender opening session” in the language of the tender dossier;
- e) the name of the tenderer.

9. Content of tenders

All tenders submitted must comply with the requirements in the tender dossier and must include:

9.1. Annex I: Application form

- 9.2. Annex II: Non - Exclusion Clauses Declaration and Declaration of Supplier Compliance to Ethic Standards
- 9.3. Annex III: Model of financial/technical offer
- 9.4. Annex IV: Work Plan for performing the task
- 9.5. Annex V: Draft Contract

And possibly:

- 9.6. A description of the commercial warranty tendered.
- 9.7. Balance sheets or extracts from balance sheets for at least the last two years for which accounts have been closed, where publication of the balance sheet is required under the company law of the country in which the economic operator is established
- 9.8. The curriculum vitae describing of the educational and professional qualifications of the person or persons responsible for providing the services/carrying out the work/responsible for the contract;
- 9.9. Appropriate statements from banks or evidence of professional risk indemnity insurance;
- 9.10. A statement of overall turnover and turnover concerning the work, supplies or services covered by the contract during a period which may be no more than the last three financial years.
- 9.11. Regarding supplies: samples, descriptions and/or authentic photographs and/or certificates drawn up by official quality control institutes or agencies of recognised competence attesting the conformity of the products with the specifications or standards in force. Regarding solar systems: scheme of installation, list of all the devices and technical specifications of each of them.

10. Pricing

- 10.1. The prices of the offers will be expressed in USD and they must be expressed on a lump sum basis that must be inclusive of all annexed costs such as taxes, transport, custom clearance, handover and work on site.
- 10.2. The prices will be considered fixed and valid for the entire duration of the contract until the complete execution of the work/delivery. No additional charge of whatsoever nature and type will be accepted by the Contracting Authority.

11. Additional information before the deadline for submission of tenders

- 11.1. The tender dossier should clearly bar the need for candidates invited to tender to request additional information during the procedure. If COOPI – COOPERAZIONE INTERNAZIONALE, either on its own initiative or in response to a request from a prospective tenderer, provides additional information on the tender dossier, it must send such information in writing to all other prospective tenderers at the same time.
- 11.2. Any prospective tenderers seeking to arrange individual meetings with either COOPI – COOPERAZIONE INTERNAZIONALE and/or ECHO during the tender period may be excluded from the tender procedure.

12. Alteration or withdrawal of tenders

- 12.1. Tenderers may alter or withdraw their tenders by written notification prior to the deadline for submission of tenders referred to in Article 8.2. No tender may be altered after this

deadline. Withdrawals must be unconditional and will end all participation in the tender procedure.

- 12.2. Any such notification of alteration or withdrawal must be prepared and submitted in accordance with Article 8. The outer envelope must be marked 'Alteration' or 'Withdrawal' as appropriate.
- 12.3. No tender may be withdrawn in the interval between the deadline for submission of tenders referred to in Article 8.2 and the expiry of the tender validity period. Withdrawal of a tender during this interval may result in forfeiture of the tender guarantee.

13. Opening of tenders

- 13.1. The tenders will be opened in public session on (04/03/2015) at COOPI...- COOPERAZIONE INTERNAZIONALE Kfarabida Branch Office by the committee appointed for the purpose. The committee will draw up minutes of the meeting, which will be available on request.
- 13.2. At the tender opening, the tenderers' names, the tender prices, written notifications of modification and withdrawal, the presence of the requisite tender guarantee and such other information as COOPI – COOPERAZIONE INTERNAZIONALE may consider appropriate must be announced.
- 13.3. After the public opening of the tenders, no information relating to the examination, clarification, evaluation and comparison of tenders, or recommendations concerning the award of the contract can be disclosed.
- 13.4. Any attempt by a tenderer to influence the evaluation committee in the process of examination, clarification, evaluation and comparison of tenders, to obtain information on how the procedure is progressing or to influence COOPI – COOPERAZIONE INTERNAZIONALE in its decision concerning the award of the contract will result in the immediate rejection of the tender.
- 13.5. All tenders received after the deadline for submission specified in the procurement notice or these instructions will be kept by COOPI – COOPERAZIONE INTERNAZIONALE. The associated guarantees may be returned to the tenderers on request. No liability can be accepted for late delivery of tenders. Late tenders will be rejected and will not be evaluated.

14. Evaluation of tenders

- 14.1. Examination of the administrative conformity of tenders:
The aim at this stage is to check that tenders comply with the essential requirements of the tender dossier. A tender is deemed to comply if it satisfies all the conditions, procedures and specifications in the tender dossier without substantially departing from or attaching restrictions to them.

Decisions to the effect that a tender is not technically compliant must be duly justified in the evaluation minutes.

If a tender does not comply with the tender dossier, it will be rejected immediately and may not subsequently be made to comply by correcting it or withdrawing the departure or restriction.
- 14.2. Technical evaluation:
After analysing the tenders deemed to comply in administrative terms, the evaluation committee will rule on the technical admissibility of each tender, classifying it as technically compliant or non-compliant.
- 14.3. To facilitate the examination, evaluation and comparison of tenders, the evaluation committee may ask each tenderer individually for clarification of their tender, including breakdowns of prices. The request for clarification and the response must be in writing only, but no change in the price or substance of the tender may be sought, offered or

permitted. Decisions to the effect that a tender is not technically compliant must be duly justified in the evaluation minutes.

14.4 Financial evaluation:

The rates and prices inserted in the bill of quantities must correspond to the conditions laid down in the tender documents (in Annex IV: Model of financial/technical offer). The financial and economic standing of the tenderer will be evaluated by the evaluation committee.

14.5 Award criteria:

The tender commission will not necessarily choose on the basis of lowest price alone but will award one of received offer on the basis of value for money, price, quality, compliance with international norms, delay for delivery. The experience of the tenderer in the performance of similar contracts will be as well a criterion for selection.

15. *Performance guarantee*

15.1. The successful tenderer will be informed in writing that its tender has been accepted (see below:notification of award). Before COOPI – COOPERAZIONE INTERNAZIONALE signs the contract with the successful tenderer, the successful tenderer must provide the documentary proof or statement required under the law of the country in which the company (or each of the companies in case of a consortium) is established, to show that it does not fall into the exclusion situations listed in declarations signed (Annex II and III of this tender dossier).

15.2. The evidence or these documents or statements must carry a date, which cannot be more than 180 days in relation to the deadline for the submission of the tender. In addition, a sworn statement shall be furnished stating that the situations described in these documents have not changed since then.

15.3. If the successful tenderer fails to provide this documentary proof or statement within 15 calendar days following the notification of award or if the successful tenderer is found to have provided false information, the award will be considered null and void. In such case, COOPI – COOPERAZIONE INTERNAZIONALE may award the tender to another tenderer or cancel the tender procedure.

16. *Signature of the contract*

16.1 Within 15 days of receipt of the contract already signed by COOPI – COOPERAZIONE INTERNAZIONALE, the selected tenderer must sign and date the contract and return it, with the performance guarantee, to the Contracting Authority. Upon signing the contract, the successful tenderer will become the Contractor and the contract will enter into force.

16.2 If the successful tenderer fails to sign and return the contract and any financial guarantee required within 15 days after receipt of notification, COOPI – COOPERAZIONE INTERNAZIONALE may consider the acceptance of the tender to be cancelled without prejudice to COOPI – COOPERAZIONE INTERNAZIONALE's right to seize the guarantee, claim compensation or pursue any other remedy in respect of such failure, and the successful tenderer will have no claim whatsoever on the Contracting Authority.

16.3 After the signature of the contract, the Contractor shall provide any detailed information requested by COOPI – COOPERAZIONE INTERNAZIONALE, ECHO, the European Anti-Fraud Office (OLAF), and the Court of Auditors, or by any other qualified outside body chosen by the Donor or by the Contracting Authority for the purposes of checking that the activities implemented in the context of the present contract are being properly carried out. The Contractor therefore allows the COOPI – COOPERAZIONE INTERNAZIONALE, ECHO, the European Anti-Fraud Office (OLAF), and the Court of Auditors to carry out the

documentary and on-the-spot checks deemed necessary by the abovementioned authorities.

17. Ethics and Exclusion clauses

- 17.1. Any attempt by a candidate or tenderer to obtain confidential information, enter into unlawful agreements with competitors or influence the committee or COOPI – COOPERAZIONE INTERNAZIONALE during the process of examining, clarifying, evaluating and comparing tenders will lead to the rejection of their candidacy or tender and may result in administrative penalties.
- 17.2. Without COOPI – COOPERAZIONE INTERNAZIONALE's prior written authorisation, a Contractor and its staff or any other company with which the Contractor is associated or linked may not, even on an ancillary or subcontracting basis, supply other services, carry out work or supply equipment for the project. This prohibition also applies to any other projects that could, owing to the nature of the contract, give rise to a conflict of interest on the part of the Contractor.
- 17.3. When putting forward a candidacy or tender, the candidate or tenderer shall declare that he is affected by no potential conflict of interest and has no particular link with other tenderers or parties involved in the project. Should such a situation arise during performance of the contract, the Contractor must immediately inform COOPI – COOPERAZIONE INTERNAZIONALE.
- 17.4. The Contractor must at all times act impartially and as a faithful adviser in accordance with the code of conduct of his profession. The Contractor shall refrain from making public statements about the project or services without COOPI – COOPERAZIONE INTERNAZIONALE's prior approval. The Contractor may not commit COOPI – COOPERAZIONE INTERNAZIONALE in any way without its prior written consent.
- 17.5. For the duration of the contract the Contractor and its staff shall respect human rights and undertake not to offend the political, cultural and religious mores of the beneficiary state.
- 17.6. The Contractor may accept no payment connected with the contract other than that provided for therein. The Contractor and its staff must not exercise any activity or receive any advantage inconsistent with their obligations to COOPI – COOPERAZIONE INTERNAZIONALE.
- 17.7. The Contractor and its staff shall be obliged to maintain professional secrecy for the entire duration of the contract and after its completion. All reports and documents drawn up or received by the Contractor shall be confidential.
- 17.8. The contract shall govern the Contracting Parties' use of all reports and documents drawn up, received or presented by them during the execution of the contract.
- 17.9. The Contractor shall refrain from any relationship likely to compromise his independence or that of its staff. If the Contractor ceases to be independent, COOPI – COOPERAZIONE INTERNAZIONALE may, regardless of injury, terminate the contract without further notice, and without the Contractor having any claim to compensation.
- 17.10. COOPI – COOPERAZIONE INTERNAZIONALE reserves the right to suspend or cancel project financing if corrupt practices of any kind are discovered at any stage of the award process and if COOPI – COOPERAZIONE INTERNAZIONALE fails to take all appropriate measures to remedy the situation. For the purposes of this provision, "corrupt practices" are the offer of a bribe, gift, gratuity or commission to any person as an inducement or reward for performing or refraining from any act relating to the award of a contract or implementation of a contract already concluded with COOPI – COOPERAZIONE INTERNAZIONALE.
- 17.11. All tenders will be rejected or contracts terminated if it emerges that the award or execution of a contract has given rise to unusual commercial expenses.

- 17.12. Such unusual commercial expenses are commissions not mentioned in the main contract or not stemming from a properly concluded contract referring to the main contract, commissions not paid in return for any actual and legitimate service, commissions remitted to a tax haven, commissions paid to a recipient who is not clearly identified or commissions paid to a company which has every appearance of being a front company.
- 17.13. The Contractor shall supply COOPI – COOPERAZIONE INTERNAZIONALE on request with all supporting documents relating to the conditions of the contract's execution. COOPI – COOPERAZIONE INTERNAZIONALE may carry out whatever documentary or on-the-spot checks it deems necessary to find evidence in cases of suspected unusual commercial expenses.
- 17.14. When putting forward a candidacy or tender, the candidate or tenderer shall declare its commitment to the non-exploitation of child labour and to the respect of basic social rights and working conditions (see declaration to be signed in Annex II). COOPI – COOPERAZIONE INTERNAZIONALE may carry out whatever documentary or on-the-spot checks it deems necessary to find evidence of the enforcement of the above mentioned principles.

18. Cancellation of the tender procedure

- 18.1. In the event of a tender procedure's cancellation, tenderers will be notified by COOPI – COOPERAZIONE INTERNAZIONALE. If the tender procedure is cancelled before the outer envelope of any tender has been opened, the sealed envelopes will be returned, unopened, to the tenderers.

Cancellation may occur where:

- the tender procedure has been unsuccessful, namely where no qualitatively or financially worthwhile tender has been received or there has been no response at all;
- the economic or technical parameters of the project have been fundamentally altered;
- exceptional circumstances or force majeure render normal performance of the project impossible;
- all technically compliant tenders exceed the financial resources available;
- there have been irregularities in the procedure, in particular where these have prevented fair competition.

In no circumstances will the Contracting Authority be liable for damages, whatever their nature (in particular damages for loss of profits) or relationship to the cancellation of a tender, even if the Contracting Authority has been advised of the possibility of damages. The publication of a procurement notice does not commit the Contracting Authority to implement the programme or project announced.

B. ANNEXES

Annex I: Application Form

Annex II: Declarations from supplier

- Non-exclusion clauses declaration
- Compliance to ethical standards declaration

Annex III: Model of financial/technical offer

Annex IV: Work plan for performing the task

Annex V: Draft contract

Annex I

Application Form

Application Form

Procurement notice: SET4food/Lebanon/01

Contract title: Energy technologies for the the ECHO SET4food pilot project in Lebanon
Lot number & lot title, if applicable:.....

One signed original application must be supplied (for each lot, if the tender procedure is divided into lots). The application must include a signed declaration using the annexed format from each legal entity making the application. **All data included in this application must concern only the legal entity or entities making the application.**

Any additional documentation (brochure, letter, etc) sent with an application will not be taken into consideration. Applications being submitted by a **consortium** (i.e., either a permanent, legally established grouping or a grouping which has been constituted informally for a specific tender procedure) must follow the instructions applicable to the consortium leader and its partners.

1 SUBMITTED by (i.e., the identity of the Candidate)

	Name(s) of legal entity or entities making this application	Nationality ⁺
Leader*		
Partner 2*		
Etc ... *		

*add / delete additional lines for consortium partners as appropriate. **Note that a sub-contractor is not considered to be a consortium partner for the purposes of this application form.** If this application is being submitted by an individual legal entity, the name of that legal entity should be entered as 'Leader' (and all other lines should be deleted). Any change in the identity of the Leader and/or any consortium partners between the deadline for receipt of applications indicated in the Procurement Notice and the award of the contract (other than for reason of changes to the legal structure of the individual entities concerned) will result in the immediate exclusion of the Candidate from the tender procedure.

⁺Country in which the legal entity is registered

2 CONTACT PERSON (for this application)

Name	
Organisation	
Address	
Telephone	
Fax	
e-mail	

3 ECONOMIC AND FINANCIAL STANDING

Please complete the following table of financial data* based on your annual accounts and your latest projections. If annual accounts are not yet available for this year or last year, please provide your latest estimates, clearly identifying estimated figures in italics. Figures in all columns must be on the same basis to allow a direct, year-on-year comparison to be made (or, if the basis has changed, an explanation of the change must be provided as a footnote to the table).

Financial data	Year before last €	Last year €	This year €	Next year €	Average ^α €
Annual revenue ^β , excluding this contract					
Net Capital					
Assets at 31/12					
Liabilities at 31/12					
Annual balance					

* if this application is being submitted by a consortium, the data in the table above must be the sum of the data in the corresponding tables in the declarations provided by the consortium partners – see point 7 of this application form.

^α Amounts entered in the 'Average' column must be the mathematical average of the amounts entered in the four preceding columns of the same row.

^β Please refer to the International Accounting Standards (relevant extracts of which are included in the attached Declaration format) for definitions of the information required.

4 STAFF RESOURCES

Please provide the following personnel statistics* for the current year and the two previous years.

Average manpower	Year before last		Last year		This year	
	Overall	Total for fields related to this contract ^ε	Overall	Total for fields related to this contract ^ε	Overall	Total for fields related to this contract ^ε
Permanent staff ^φ						
Other staff ^γ						
Total						
Permanent staff as a proportion of total staff (%)	%	%	%	%	%	%

* if this application is being submitted by a consortium, the data in the table above must be the sum of the data in the corresponding tables in the declarations provided by the consortium partners – see point 7 of this application form.

^ε corresponding to the relevant specialisations identified in point 5 below

^φ staff directly employed by the Candidate on a permanent basis (i.e., under indefinite contracts)

^γ other staff not directly employed by the Candidate on a permanent basis (i.e., under fixed-term contracts)

5 EXPERIENCE

<p>1. Number of years of experience in implementing tasks similar to the object of the contract (in the past three years)</p> <ul style="list-style-type: none"> - Name of the implementing partner and name of the contact person for references - Brief description of the task carried out and location 	
<p>2. Main collaboration with international Organisations and NGOs (in the past three years)</p> <ul style="list-style-type: none"> - Name of the implementing partner and name of the contact person for references - Brief description of the task carried out and location 	

6 STATEMENT

I, the undersigned, being the authorised signatory of the above Candidate (including all consortium partners, in the case of a consortium), hereby declare that we have examined the procurement notice for the tender procedure referred to above.

We recognise that our tender will be excluded if we propose key experts who have been involved in preparing this project or engage such personnel as advisers in the preparation of our tender, and that we may also be subject to exclusion from other tender procedures and contracts funded by the EC.

We are fully aware that, in the case of a consortium, the composition of the consortium cannot be modified in the course of the tender procedure. We are also aware that the consortium partners would have joint and several liability towards the Contracting Authority concerning participation in both the above tender procedure and any contract awarded to us as a result of it.

This tender is valid for a period of (.....) from the final date for submission of tenders, i.e. until (././.).

We have examined and accept in full the content of the dossier for invitation to tender No. (.....) of (././.). We hereby accept its provisions in their entirety, without reservation or restriction.

We offer to deliver, in accordance with the terms of the tender dossier and the conditions and time limits laid down, without reserve or restriction:

(if applicable:)

Lot no. (...): (description of supplies with indication of quantities)

Lot no. (...):(description of supplies with indication of quantities)

As detailed in the technical annexes

Signed on behalf of the Candidate

Name	
Signature	
Date	

Annex II

Declarations from supplier

- Non-exclusion clauses declaration
- Compliance to ethical standards declaration

Non-exclusion clauses declaration

To be completed and signed by the tenderer (including one from each partner in a consortium).

The undersigned.....

Owner of the Company/Organization:

Located in: Address.....

Country.....

Tel./Fax.....e-mail.....

Declares that the company run and operated by the undersigned and myself:

1. We have examined and accept in full the content of the dossier for invitation to tender No. (.....) of (.././..). We hereby accept its provisions in their entirety, without reservation or restriction.
2. We are submitting this application in our own right and (as partner in the consortium led by (name of the leader / ourselves.)) for this tender (Lot No). We confirm that we are not tendering for the same contract in any other form. (We confirm, as a partner in the consortium, that all partners are jointly and severally liable by law for the performance of the contract, that the lead partner is authorised to bind and receive instructions for and on behalf of each member, that the performance of the contract, including payments, is the responsibility of the lead partner, and that all partners in the joint venture/consortium are bound to remain in the joint venture/consortium for the entire period of the contract's performance).
3. We are not in any of the situations excluding us from participating in contracts which are listed in Article 17 of the instructions to tenderers and in this declaration. In the event that our tender is successful, we undertake to provide the proof usual under the law of the country in which we are established that we do not fall into the exclusion situations listed in article 17. The date on the evidence or documents provided will be no earlier than 180 days before the deadline for submission of tenders and, in addition, we will provide a sworn statement that our situation has not altered in the period which has elapsed since the evidence in question was drawn up.
4. We also understand that if we fail to provide this proof within 15 calendar days after receiving the notification of award, or if the information provided is proved false, the award will be considered null and void.
5. We agree to abide by the ethics clauses that we have no potential conflict of interests or any relation with other candidates or other parties in the tender procedure at the time of the submission of this application.
6. We declare that we not fall into one of the following situations and shall be excluded from participation in a procurement procedure (articles 93 and 94 relative to EU Financial regulations) if we:
7. are bankrupt or being wound up, are having affairs administered by the courts, have entered into an arrangement with creditors, have suspended business activities, are the subject of proceedings concerning those matters, or are in any analogous situation arising from a similar procedure provided for in national legislation or regulations.



8. Have been convicted of an offence concerning professional conduct by a judgment which has the force of res judicata.
9. Have been guilty of grave professional misconduct
10. Have not fulfilled obligations relating to the payment of social security contributions or the payment of taxes in accordance with the legal provisions of the country in which we are established or with those of the country of the contracting authority or those of the country where the contract is to be performed.
11. Have been the subject of a judgment which has the force of res judicata for fraud, corruption, involvement in a criminal organization or any other illegal activity detrimental to the Communities' financial interests.
12. Have been declared to be in serious breach of contract for failure to comply with contractual obligations.
13. We will inform the Contracting Authority immediately if there is any change in the above circumstances at any stage during the implementation of the contract. We also fully recognise and accept that any inaccurate or incomplete information deliberately provided in this application may result in our exclusion from this and other contracts funded by the European Communities.
14. We note that the Contracting Authority is not bound to proceed with this invitation to tender and that it reserves the right to award only part of the contract. It will incur no liability towards us should it do so.

Name and surname: (.....)

Duly authorised to sign this tender on behalf of:

(.....)

Place and date: (.....)

Stamp of the firm/company:

Compliance to ethical standards declaration

The undersigned.....

Owner of the Company/Organization:

Located in: Address.....
Country.....

Tel./Fax.....e-mail.....

Declares that the company run and operated by the undersigned has not been convicted of or under investigation of any criminal offence or activity such as the following:



- manufacturing or commercialization of arms;
- activities producing serious negative impact on persons or the environment;
- employment of persons below the minimum legal age for employment;
- violation of civil rights;
- violation of workers' rights;
- scientific experimentation on weak or defenseless individuals or animals;
- exclusion/marginalization of minorities or entire categories of a population;
- direct relationship of complicity with a regime that notoriously disrespects human rights and/or is responsible for seriously compromising the environment;
- pornography, commodification of sex and pedophilia;
- gambling.

I furthermore declare to be fully aware that if the present declaration results false, in part or in whole, COOPI – COOPERAZIONE INTERNAZIONALE has the right to null and void the present contract with my company or organization without notice.

In faith,

Location, date

Signature (and rubber stamped)



Annex III
Model of financial/technical offer

Model of financial/technical offer

PUBLICATION REFERENCE: (SET4food/Lebanon/01) **LOT 1** **NAME OF TENDERER:** (.....)

A	B	C	D	E
ARTICLE	QUANTITY	DESCRIPTION OF ARTICLE	UNIT COSTS WITH DELIVERY AND ANY TAXATION (PLACE OF ACCEPTANCE) CURRENCY	TOTAL CURRENCY
Supply and delivery of solar-home-systems in DC. Each system will provide lighting and power	25			

Done at:(.....), (.././..)
On behalf of (.....)

by (name)
(tenderer's stamp and signature)

Model of financial/technical offer

PUBLICATION REFERENCE: (SET4food/Lebanon/01) **LOT 2** **NAME OF TENDERER:** (.....)

A	B	C	D	E
ARTICLE	QUANTITY	DESCRIPTION OF ARTICLE	UNIT COSTS WITH DELIVERY AND ANY TAXATION (PLACE OF ACCEPTANCE) CURRENCY	TOTAL CURRENCY
Supply and installation of self-assembled solar-home-systems in DC. Each system will provide lighting to a household and power to a thermoelectric refrigerator	13			

Done at:(.....), (././.)
On behalf of (.....)

by (name)
(tenderer's stamp and signature)



Model of financial/technical offer

PUBLICATION REFERENCE: (SET4food/Lebanon/01) **LOT 3** **NAME OF TENDERER:** (.....)

A	B	C	D	E
ARTICLE	QUANTITY	DESCRIPTION OF ARTICLE	UNIT COSTS WITH DELIVERY AND ANY TAXATION (PLACE OF ACCEPTANCE) CURRENCY	TOTAL CURRENCY
Supply and installation of a solar system in the settlement close to Hollow blocks factory, Chekka, Batroun District. This system will provide lighting to 20 households and power to 5 refrigerators	1			

Done at:(.....), (.././..)

On behalf of (.....)

by (name)

(tenderer's stamp and signature)



Model of financial/technical offer

PUBLICATION REFERENCE: (SET4food/Lebanon/01) **LOT 4** **NAME OF TENDERER:** (.....)

A	B	C	D	E
ARTICLE	QUANTITY	DESCRIPTION OF ARTICLE	UNIT COSTS WITH DELIVERY AND ANY TAXATION (PLACE OF ACCEPTANCE) CURRENCY	TOTAL CURRENCY
Supply and installation of a hybrid (solar and wind) system in Waha Center, Deddeh, Koura district. This system will provide power to 8 refrigerators	1			

Done at:(.....), (././..)
On behalf of (.....)

by (name)
(tenderer's stamp and signature)



Model of financial/technical offer

PUBLICATION REFERENCE: (SET4food/Lebanon/01) **LOT 5** **NAME OF TENDERER:** (.....)

A	B	C	D	E
ARTICLE	QUANTITY	DESCRIPTION OF ARTICLE	UNIT COSTS WITH DELIVERY AND ANY TAXATION (PLACE OF ACCEPTANCE) CURRENCY	TOTAL CURRENCY
Supply and delivery of vacuum sealer systems for packaging for food preservation. Each system has to be composed of 1 vacuum sealer hand-pump (not electrical) and 30 three quart-size vacuum freezer bags	25			

Done at:(.....), (././.)
On behalf of (.....)

by (name)
(tenderer's stamp and signature)



Model of financial/technical offer

PUBLICATION REFERENCE: (SET4food/Lebanon/01) **LOT 6** **NAME OF TENDERER:** (.....)

A	B	C	D	E
ARTICLE	QUANTITY	DESCRIPTION OF ARTICLE	UNIT COSTS WITH DELIVERY AND ANY TAXATION (PLACE OF ACCEPTANCE) CURRENCY	TOTAL CURRENCY
Production and delivery of ELSA cookstoves, scale 1:2.24	25			

Done at:(.....), (././.)
On behalf of (.....)

by (name)
(tenderer's stamp and signature)



Model of financial/technical offer

PUBLICATION REFERENCE: (SET4food/Lebanon/01) **LOT 7** **NAME OF TENDERER:** (.....)

A	B	C	D	E
ARTICLE	QUANTITY	DESCRIPTION OF ARTICLE	UNIT COSTS WITH DELIVERY AND ANY TAXATION (PLACE OF ACCEPTANCE) CURRENCY	TOTAL CURRENCY
Production and delivery of pot skirts for moveable gas burner	13			

Done at:(.....), (././.)
On behalf of (.....)

by (name)
(tenderer's stamp and signature)



Model of financial/technical offer

PUBLICATION REFERENCE: (SET4food/Lebanon/01) **LOT 8** **NAME OF TENDERER:** (.....)

A	B	C	D	E
ARTICLE	QUANTITY	DESCRIPTION OF ARTICLE	UNIT COSTS WITH DELIVERY AND ANY TAXATION (PLACE OF ACCEPTANCE) CURRENCY	TOTAL CURRENCY
Supply and delivery of pressure cookers, 6 liters, safety valve	67			

Done at:(.....), (././.)
On behalf of (.....)

by (name)
(tenderer's stamp and signature)



Model of financial/technical offer

PUBLICATION REFERENCE: (SET4food/Lebanon/01) **LOT 9** **NAME OF TENDERER:** (.....)

A	B	C	D	E
ARTICLE	QUANTITY	DESCRIPTION OF ARTICLE	UNIT COSTS WITH DELIVERY AND ANY TAXATION (PLACE OF ACCEPTANCE) CURRENCY	TOTAL CURRENCY
Supply and delivery of portable UV water purification devices, equipped with a battery and charged by either an integrated solar panel, or a USB cable	13			

Done at:(.....), (././.)
On behalf of (.....)

by (name)
(tenderer's stamp and signature)



Model of financial/technical offer

PUBLICATION REFERENCE: (SET4food/Lebanon/01)

LOT 10

NAME OF TENDERER: (.....)

A	B	C	D	E
ARTICLE	QUANTITY	DESCRIPTION OF ARTICLE	UNIT COSTS WITH DELIVERY AND ANY TAXATION (PLACE OF ACCEPTANCE) CURRENCY	TOTAL CURRENCY
Supply and delivery of portable UV water purification devices, equipped with a battery and charged by either an integrated solar panel, or a USB cable	13			

Done at:(.....), (././.)
On behalf of (.....)

by (name)
(tenderer's stamp and signature)



Annex IV
Work plan for performing the task
(if necessary)

Annex V
Draft contract

Draft contract

COOPI – COOPERAZIONE INTERNAZIONALE hereinafter referred to as "The Contracting Authority", represented by (name of the representative)

of the one party, and

(Name of the successful tender) (acronym) hereinafter referred to as "the Contractor" (name of the representative)

of the other party,

have agreed as follows:

Article 1 Subject

1.1 COOPI – COOPERAZIONE INTERNAZIONALE has received a grant from the European Commission Humanitarian Office (ECHO) for the implementation of the operation entitled "Sustainable energy technologies for food utilization (SET4food)" and intends to apply a portion of that grant to payments under this contract. The donor will establish the final amount of the grant and will liquidate it to COOPI – COOPERAZIONE INTERNAZIONALE on completion of the operation on the basis of the expenses presented and declared eligible. No party other than COOPI – COOPERAZIONE INTERNAZIONALE shall derive any rights from the grant or have any claim to its proceeds. Under no circumstances or for no reason whatsoever will the donor entertain any request for indemnity or payment directly submitted by the humanitarian organisation's contractors.

1.2 The subject of the contract is the delivery of the following supplies or installation of the following systems by the Contractor in Syrian refugee informal settlements in Koura and Batroun districts:

- **LOT 1:** Supply and delivery of twenty-five (25) solar-home-systems in DC. Each system will provide lighting and power.

Each system has to be composed as follows:

- 1 PV panel, 30 W @ 12 V;
- 1 battery 20 Ah @ 12 V;
- 1 Charge controller suitable for the system (at least 3 A);
- 2 LED inside lights, 5W each, for indoor use;
- 2 LED security lights, 5W each, for outdoor use;
- 1 USB port;
- An adequate wiring;
- Other items (e.g. lamp holders) or fittings required to install the system and to make it operational.

The system can be either a solar kit or self-assembled. In any case, the system has to be easy and safe to connect and disconnect also for non-technical people.

The Contractor is in charge of the shipping of all the materials to COOPI – COOPERAZIONE INTERNAZIONALE in ~~Kfarabida Branch Office~~. All the costs have to be incorporated in the bid, including any taxation. The supply will be considered effectively delivered only when received by a COOPI – COOPERAZIONE INTERNAZIONALE representative, based on the release of a written certificate of delivery.

All the materials have to be covered by a warranty whose minimum duration is 10 months after provisional acceptance.

When the Contractor is selected, COOPI – COOPERAZIONE INTERNAZIONALE may request the supply and delivery of other solar-home-systems with the same characteristics above-mentioned, up to a maximum of forty (40). The price of such an extra-supply will be directly negotiated by COOPI – COOPERAZIONE INTERNAZIONALE with the Contractor.

- **LOT 2:** Supply and installation of thirteen (13) self-assembled solar-home-systems in DC. Each system will provide lighting to a household and power to a thermoelectric refrigerator.

Each system has to be composed as follows:

- 1 PV panel, 200 W @ 12 V;
- 1 battery 80 Ah @ 12 V;
- 1 Charge controller suitable for the system (at least 20 A);
- 1 Thermoelectric fridge with capacity between 20 and 40 l, in DC, 12 V, maximum power absorption 50 W, maximum power consumption in standard testing conditions (STC) 300 Wh/day;
- 2 LED inside lights, 5W each, for indoor use;
- 2 LED security lights, 5W each, for outdoor use;
- 1 fuse DC (50 A);
- An adequate wiring and switchers for the LEDs;
- Other items (e.g. lamp holders) or fittings required to install the system and to make it operational.

The system has to be easy to connect and disconnect.

The Contractor is in charge of the shipping of all the materials to Kfarsaroun, Koura District, and the installation in the 13 households selected. All the costs have to be incorporated in the bid, including any taxation. The system has to be installed in compliance with local national regulation, and to ensure the safety of both the workers involved, and the users of the system. The system will be considered effectively installed only after a visit by a COOPI – COOPERAZIONE INTERNAZIONALE representative, based on the release of a written certificate of completion.

All the materials have to be covered by a warranty whose minimum duration is 10 months after provisional acceptance.

- **LOT 3:** Supply and installation of one (1) solar system in the settlement close to Hollow blocks factory, Chekka, Batroun District. This system will provide lighting to 20 households and power to 5 refrigerators.

The system has to be composed as follows:

- PV panel for a total power of 2.5 kW @ 24 V (e.g. 8 strings of 300 W @ 24 V);
- Batteries 500 Ah @ 24 V in series;
- A suitable number of charge controllers will be required, in order to manage a DC current up to 100 A;
- 1 inverter suitable for the system (2 kW);
- 40 LED inside lights, 5W each, for indoor use (2 per each household);
- 40 LED security lights, 5W each, for outdoor use (2 per each household);
- 5 extra sockets (where refrigerators are located);
- 5 compressor refrigerators, each one with capacity between 100 and 250 l, in AC, 220-240 V, maximum power absorption 100 W, maximum power consumption in standard testing conditions (STC) 300 Wh/day;
- An adequate wiring and switchers for the loads;
- 1 fuse DC (200 A);
- 1 isolator switch;
- Other devices, items (e.g. lamp holders, frames for PV panel installation) or fittings required to install the system and to make it operational.
- 1 Power Meters AC (Single Phase DIN-rail Type Kilowatt Hour kWh Meter 220V);
- 1 Miniature circuit breaker (MCB) with protected neutral LN, C, 16A, 6 kA

The tenderer is invited to survey the site, in order to propose the most suitable installation scheme. However any cost related to preliminary activities like this will not be covered by COOPI, no matter the tenderer will be contracted or will not.

The Contractor is in charge of the shipping of all the materials to the settlement close to Hollow blocks factory, Chekka, Batroun District, and of the installation of the system, including lights inside all the 20 households selected. All the wirings, fittings and any other device or accessory required for a complete and effective installation of the system have to be provided by the Contractor, as well as any civil work, if required. The system has to be installed in compliance with local national regulation, and to ensure the safety of both the workers involved, and the users of the system.

All the costs have to be incorporated in the bid, including any taxation. The system will be considered effectively installed only after a visit by a COOPI – COOPERAZIONE INTERNAZIONALE representative, based on the release of a written certificate of completion.

All the materials have to be covered by a warranty whose minimum duration is 10 months after provisional acceptance.

- **LOT 4:** Supply and installation of one (1) hybrid (solar and wind) system in Waha Center, Deddeh, Koura district. This system will provide power to 8 refrigerators to be installed in the Waha Center.

The system has to be composed as follows (on possible configuration depicted in the picture below):

- 1 horizontal-axis wind turbine, 2.5 kW

- One system with solar PV panels, polycrystalline technology, total power installed 6 kW;
 - Batteries (25 kWh);
 - 1 or more charge controllers suitable for the PV system;
 - 1 or more charge controllers suitable for the WIND system
 - As an option a unique charge controller (able to manage both PV and WIND generator) may be adopted
 - 1 inverter suitable for the system (5 kW);
 - 8 refrigerators, each one with 8 independent lockable compartments, a global capacity between 400 and 700 l, maximum absorption 350W, maximum power consumption in standard testing conditions (STC) 3600 Wh/day. All the refrigerators have to be equipped with eutectic plates for static cooling or another device with comparable performance;
 - 2 Power Meters AC (Single Phase DIN-rail Type Kilowatt Hour kWh Meter 220V);
 - 1 DC Energy Meter suitable for each DC line.
 - 1 Miniature circuit breaker (MCB) with protected neutral LN, C, 16A, 6 kA
 - 3 Miniature circuit breaker (MCB) with protected neutral LN, C, 10A, 6 kA
 - 1 suitable fuse for each DC line
 - 1 isolator switch for each DC line + 1 after the output of the Battery bank
 - 1 Power outlet 16 A
 - 3 Power outlet 10 A
 - 1 switchboard (DIN-rail) devoted to integrate all the listed component
 - An adequate wiring and switchers for the loads;
- Other items or fittings required for a full installation of the system and to make it operational

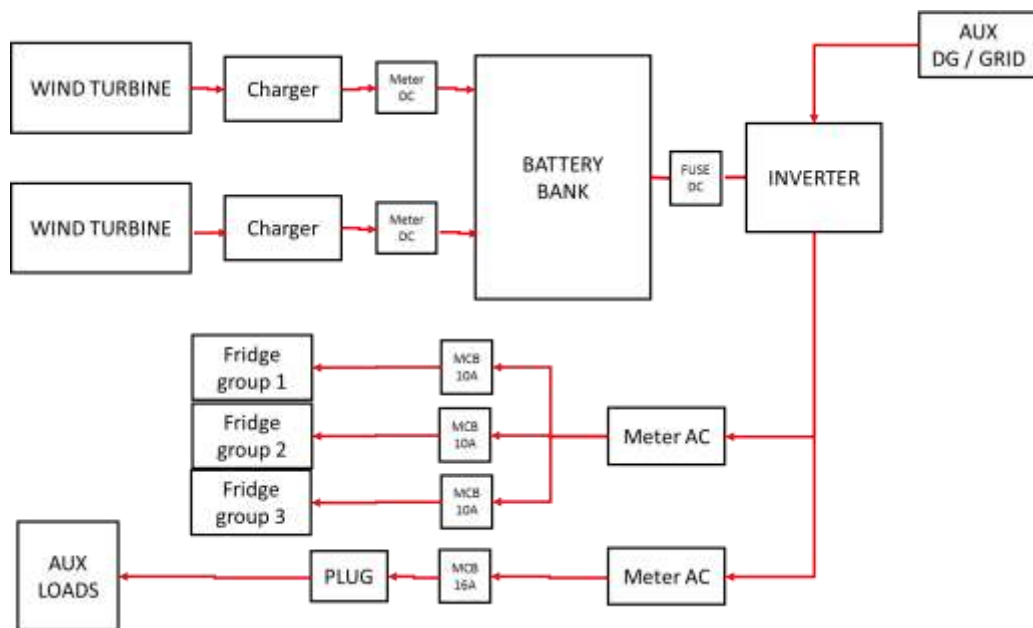

Example of the possible configuration

The tenderer is invited to survey the site, in order to propose the most suitable installation scheme. However any cost related to preliminary activities like this will not be covered by COOPI, no matter the tenderer will be contracted or will not.

Solar panels and wind turbine will be installed on the roof of the Waha Center. Batteries, charge controllers, inverter and all the devices will be properly accommodated to ensure their operation and safety, as well as user's safety.

Refrigerators will be installed inside the Waha Center, 2 per floor, as it will be indicated by COOPI – COOPERAZIONE INTERNAZIONALE.

The Contractor is in charge of the shipping of all the materials to Waha Center, Deddeh, Koura district, and of the installation of the system. . All the wirings, fittings and any other device, item or accessory required for a complete and effective installation of the system have to be provided by the Contractor, as well as any civil work, if required. The system has to be installed in compliance with local national regulation, and to ensure the safety of both the workers involved, and the users of the system.

All the costs have to be incorporated in the bid, including any taxation. The system will be considered effectively installed only after a visit by a COOPI – COOPERAZIONE INTERNAZIONALE representative, based on the release of a written certificate of completion.

All the materials have to be covered by a warranty whose minimum duration is 10 months after provisional acceptance.

- **LOT 5:** Supply and delivery of twenty-five (25) vacuum sealer systems for packaging for food preservation. Each system has to be composed of 1 vacuum sealer hand-pump (not electrical) and 30 three quart-size vacuum freezer bags.

During the evaluation of tenders, COOPI – COOPERAZIONE INTERNAZIONALE may request to check a sample of the supply proposed in Kfarabida Branch Office or in any other COOPI – COOPERAZIONE INTERNAZIONALE branch office. If this sample is not available, the Contractor will be automatically excluded.

The Contractor is in charge of the shipping of all the materials to COOPI – COOPERAZIONE INTERNAZIONALE office in Kfaraabida. All costs have to be incorporated in the bid, including any taxation. The supply will be considered effectively delivered only when received by a COOPI – COOPERAZIONE INTERNAZIONALE representative, based on the release of a written certificate of delivery.

All the materials have to be covered by a warranty whose minimum duration is 10 months after provisional acceptance.

When the Contractor is selected, COOPI – COOPERAZIONE INTERNAZIONALE may request the supply and delivery of other outdoor lighting systems with the same characteristics above-mentioned, up to a maximum of forty (40). The price of such an extra-supply will be directly negotiated by COOPI – COOPERAZIONE INTERNAZIONALE with the Contractor.

- **LOT 6:** Production and delivery of twenty-five (25) ELSA cookstoves. Each cookstove has to be produced according to the official blueprint and assembled according to the construction manual. Both the blueprint (drawings) and the manual are attached or can be downloaded for free by <http://www.blucomb.com/product/elsa-blueprint-pdf/>. The model with scale 1:2.24 has to be considered. The cookstove has to be produced in stainless steel, grade 316 or 306, thickness 0.5 or 0.6 mm.

The Contractor is in charge of the shipping of all the materials to COOPI – COOPERAZIONE INTERNAZIONALE office in Kfaraabida. All costs have to be incorporated in the bid, including any taxation. The supply will be considered effectively delivered only when received by a COOPI – COOPERAZIONE INTERNAZIONALE representative, based on the release of a written certificate of delivery.

All the materials have to be covered by a warranty whose minimum duration is 10 months after provisional acceptance.

- **LOT 7:** Production and delivery of thirteen (13) pot skirts for moveable gas burner. Each pot skirt has to be produced according to the drawings attached (please, consider a diameter of the pot of 40 cm). However the pot skirt has to be appropriate for gas burners most commonly used by Syrian refugees in Lebanon. The pot skirt has to be produced in stainless steel, grade 316 or 306, thickness 0.5 mm.

The first sample produced has to be tested with an adequate burner and a pot appointed by COOPI – COOPERAZIONE INTERNAZIONALE. If this sample is approved by COOPI – COOPERAZIONE INTERNAZIONALE, the production will proceed up to the quantity contracted. If the sample is not approved, the Contractor will have to manufacture a new sample able to meet the requirements without any extra cost for COOPI – COOPERAZIONE INTERNAZIONALE. All the pot skirts produced will have to meet the requirements.

The Contractor is in charge of the shipping of all the materials to COOPI – COOPERAZIONE INTERNAZIONALE office in Kfaraabida. All costs have to be incorporated in the bid, including any taxation. The supply will be considered effectively delivered only when received by a COOPI – COOPERAZIONE INTERNAZIONALE representative, based on the release of a written certificate of delivery.

All the materials have to be covered by a warranty whose minimum duration is 10 months after provisional acceptance.

When the Contractor is selected, COOPI – COOPERAZIONE INTERNAZIONALE may request the supply and delivery of other pot skirts with the same characteristics above-mentioned, up to a maximum of twenty (20). The price of such an extra-supply will be

directly negotiated by COOPI – COOPERAZIONE INTERNAZIONALE with the Contractor.

- **LOT 8:** Supply and delivery of sixty-seven (67) pressure cookers. Each pressure cooker will have a capacity of 6 liters, and will be equipped with a safety valve.

During the evaluation of tenders, COOPI – COOPERAZIONE INTERNAZIONALE may request to check a sample of the supply proposed in Kfaraabida or in any other COOPI – COOPERAZIONE INTERNAZIONALE branch office. If this sample is not available, the Contractor will be automatically excluded.

The Contractor is in charge of the shipping of all the materials to COOPI – COOPERAZIONE INTERNAZIONALE office in Kfaraabida. All costs have to be incorporated in the bid, including any taxation. The supply will be considered effectively delivered only when received by a COOPI – COOPERAZIONE INTERNAZIONALE representative, based on the release of a written certificate of delivery.

All the materials have to be covered by a warranty whose minimum duration is 10 months after provisional acceptance.

When the Contractor is selected, COOPI – COOPERAZIONE INTERNAZIONALE may request the supply and delivery of other pressure cookers with the same characteristics above-mentioned, up to a maximum of sixty-seven (67). The price of such an extra-supply will be directly negotiated by COOPI – COOPERAZIONE INTERNAZIONALE with the Contractor.

- **LOT 9:** Supply and delivery of thirteen (13) portable UV water purification devices. Each device has to be proven to be effective to remove at least 99% of microbiological contamination. It has to be equipped with a battery and charged by either an integrated solar panel, or a USB cable.

During the evaluation of tenders, COOPI – COOPERAZIONE INTERNAZIONALE may request to check a sample of the supply proposed in Kfaraabida or in any other COOPI – COOPERAZIONE INTERNAZIONALE branch office. If this sample is not available, the Contractor will be automatically excluded.

The Contractor is in charge of the shipping of all the materials to COOPI – COOPERAZIONE INTERNAZIONALE office in Kfaraabida. All costs have to be incorporated in the bid, including any taxation. The supply will be considered effectively delivered only when received by a COOPI – COOPERAZIONE INTERNAZIONALE representative, based on the release of a written certificate of delivery.

All the materials have to be covered by a warranty whose minimum duration is 10 months after provisional acceptance.

When the Contractor is selected, COOPI – COOPERAZIONE INTERNAZIONALE may request the supply and delivery of other water purification devices with the same characteristics above-mentioned, up to a maximum of twelve (12). The price of such an extra-supply will be directly negotiated by COOPI – COOPERAZIONE INTERNAZIONALE with the Contractor.

- **LOT 10:** Supply and delivery of thirteen (13) portable UV water purification devices. Each device has to be proven to be effective to remove at least 99% of microbiological contamination. It has to be equipped with a battery and charged by either an integrated solar panel, or a USB cable.

During the evaluation of tenders, COOPI – COOPERAZIONE INTERNAZIONALE may request to check a sample of the supply proposed in Kfaraabida or in any other COOPI

– COOPERAZIONE INTERNAZIONALE branch office. If this sample is not available, the Contractor will be automatically excluded.

The Contractor is in charge of the shipping of all the materials to COOPI – COOPERAZIONE INTERNAZIONALE office in Kfaraabida. All costs have to be incorporated in the bid, including any taxation. The supply will be considered effectively delivered only when received by a COOPI – COOPERAZIONE INTERNAZIONALE representative, based on the release of a written certificate of delivery.

All the materials have to be covered by a warranty whose minimum duration is 10 months after provisional acceptance.

When the Contractor is selected, COOPI – COOPERAZIONE INTERNAZIONALE may request the supply and delivery of other water purification devices with the same characteristics above-mentioned, up to a maximum of twelve (12). The price of such an extra-supply will be directly negotiated by COOPI – COOPERAZIONE INTERNAZIONALE with the Contractor.

- 1.3 The Contractor shall comply strictly with all the terms of the Conditions and the technical specifications in this Contract (including any changes under the proposed variant).
- 1.4 The place of acceptance of the supplies shall be the COOPI – COOPERAZIONE INTERNAZIONALE Kfarabida Branch Office, the time limits for delivery shall be 2 weeks after the signature of the contract.
- 1.5 The Contractor shall provide any detailed information requested by the Contracting Authority, the European Commission, other Donors, the European Anti-Fraud Office (OLAF), and the Court of Auditors, or by any other qualified outside body chosen by the Donor or by the Contracting Authority for the purposes of checking that the activities implemented in the context of the present contract are being properly carried out. The Contractor therefore allows the Contracting Authority, the European Commission, other Donors, the European Anti-Fraud Office (OLAF), and the Court of Auditors to carry out the documentary and on-the-spot checks deemed necessary by the abovementioned authorities.

Article 2 Price

- 2.1 The contractor acknowledges the content of the technical specifications and will execute the task as described in the subject for the total amount of:

..... **USD**

- 2.2 The price referred to in Article 2.1 above shall be the sole remuneration owed by the Contracting Authority to the Contractor under the contract. It shall be firm and shall not be subject to revision.
- 2.3 Since the Contractor is deemed to have determined its prices on the basis of its own calculations, operations and estimates, it shall, at no additional charge, carry out any work that is the subject of any item in the tender for which the Contractor indicates neither a unit price nor a lump sum.

Article 3 Order of precedence of contract documents

The contract is made up of the following documents, in order of precedence:



- the contract agreement;
- the Contractor's tender, including annexes
- other provisions of the tender dossier.

The various documents making up the contract shall be deemed to be mutually explanatory; in cases of ambiguity or divergence, they should be read in the order in which they appear above.

Article 4 General Obligations

- 4.1 The Contractor shall perform the contract with due care and diligence including, where specified, the design, manufacture, delivery to site, erecting, testing and commissioning of the supplies and carrying out of any other work including the remedying of any defects in the supplies. The Contractor shall also provide all necessary equipment, supervision, labour and facilities required for the performance of the contract.
- 4.2 The Contractor shall respect and abide by all laws and regulations in force in the state of the Contracting Authority and shall ensure that its personnel, their dependants, and its local employees also respect and abide by all such laws and regulations. The Contractor shall indemnify the Contracting Authority against any claims and proceedings arising from any infringement by the Contractor, its employees and their dependants of such laws and regulations.
- 4.3 The Contractor shall treat all documents and information received in connection with the contract as private and confidential. It shall not, save insofar as may be necessary for the purposes of the contract's execution, publish or disclose any particulars of the contract without the prior written consent of the Contracting Authority or the Project Manager. If any disagreement arises as to the necessity for any publication or disclosure for the purpose of the contract, the decision of the Contracting Authority shall be final.
- 4.4 The Contractor shall be bound by the documents that form its tender dossier that are annexed to the present contract.

Article 5 Period of Execution

5.12 Weeks after the signature of the contract

Article 6 Warranty

The Contractor shall warrant that the supplies are new, unused, of the most recent models and incorporate all recent improvements in design and materials. The Contractor shall further warrant that none of the supplies have any defect arising from design, materials or workmanship. This warranty shall remain valid for 10 months after provisional acceptance.

Article 7 Payments

- 7.1 (10%) of the total amount specified in this contract shall be paid by the Contracting Authority as advance payment
- 7.2 All payments following the advance will take place according and proportionally to the execution of the task and they will be paid as specified in the commercial invoice handed over to the Contracting Authority by the Contractor



Article 8 Delivery

The Contractor shall bear all risks relating to the goods until provisional acceptance at destination. The supplies shall be packaged so as to prevent their damage or deterioration in transit to their destination.

Article 9 Delay

In case of delay in the execution of the task, a penalty of per day will be applied to the Contractor.

Article 10 Disputes

All disputes between contractual parties arising from implementation of the tasks herein that cannot be automatically settled, shall be referred to the exclusive jurisdiction of the Italian court.

Article 11 Termination of the contract

11.1 The Contracting Authority may, after giving the Contractor seven days' notice, terminate the contract in any of the following cases:

- a) the Contractor substantially fails to perform its obligations under this contract;
- b) the Contractor fails to comply within a reasonable time with a notice given by the Project Manager requiring him to perform his obligations under the contract which seriously affects the proper and timely performance of the work;
- c) the Contractor refuses or neglects to carry out administrative orders given by the Project Manager;
- d) the Contractor assigns the contract or subcontracts without the authorisation of the Contracting Authority;
- e) the Contractor is bankrupt or being wound up, is having its affairs administered by the courts, has entered into an arrangement with creditors, has suspended business activities, is the subject of proceedings concerning those matters, or is in any analogous situation arising from a similar procedure provided for in national legislation or regulations;
- f) the Contractor has been convicted of an offence concerning professional conduct by a judgment which has the force of res judicata;
- g) the Contractor has been guilty of grave professional misconduct proven by any means which the Contracting Authority can justify;
- h) the Contractor has been the subject of a judgment which has the force of res judicata for fraud, corruption, involvement in a criminal organisation or any other illegal activity detrimental to the Communities' financial interests;
- i) the Contractor, following another procurement procedure or grant award procedure financed by the Community budget, has been declared to be in serious breach of contract for failure to perform its contractual obligations;
- j) any organisational modification occurs involving a change in the legal personality, nature or control of the Contractor, unless such modification is recorded in an addendum to the contract;
- k) any other legal disability hindering performance of the contract occurs;

- l) the Contractor fails to provide the required guarantee or insurance, or if the person providing the earlier guarantee or insurance required under the present contract is not able to abide by its commitments.
- m) The Contracting Authority during the course of documentary or on-the-spot checks discovers an infringement of the Contractor concerning the non-exploitation of child labour and the respect of basic social rights and working conditions.

11.3 In the event of termination, the Project Manager shall, as soon as possible and in the presence of the Contractor or his representatives or having duly summoned them, draw up a report on the supplies delivered and the work performed and take an inventory of the materials supplied and unused. A statement shall also be drawn up of monies due to the Contractor and of monies owed by the Contractor to the Contracting Authority as at the date of termination of the contract.

11.4 This contract shall be automatically terminated if it has given risen to no payment in the three years following its signing.

Article 12 Termination by the Contractor

12.1 The Contractor may, after giving 14 days' notice to the Contracting Authority, terminate the contract if the Contracting Authority:

- fails to pay the Contractor the amounts due under any certificate issued by the Project Manager after the expiry of the deadline stated in the Special Conditions;
- consistently fails to meet its obligations after repeated reminders; or
- suspends the delivery of the supplies, or any part thereof, for more than 180 days, for reasons not specified in the contract or not attributable to the Contractor.

12.2 In the event of such termination, the Contracting Authority shall pay the Contractor for any loss or damage the Contractor may have suffered.

Article 13 Force majeure

13.1 Neither Party shall be considered to be in default or in breach of its obligations under the contract if the performance of such obligations is prevented by any event of force majeure arising after the date of notification of award or the date when the contract becomes effective, whichever is earlier.

13.2 For the purposes of this Article, the term "force majeure" means strikes, lock-outs or other industrial disturbances, wars whether declared or not, blockades, insurrection, riots, epidemics, landslides, earthquakes, storms, lightning, floods, washouts, civil disturbances, explosions and any other similar unforeseeable events which are beyond the Parties' control and cannot be overcome by due diligence.

13.3 If circumstances of force majeure have occurred and continue for a period of 180 days then, notwithstanding any extension of time for completion of the contract that the Contractor may by reason thereof have been granted, either Party shall be entitled to serve the other with 30 days' notice to terminate the contract. If, on the expiry of the period of 30 days, the situation of force majeure still applies, the contract shall be terminated and, by virtue of the law governing the contract, the Parties shall be released from further performance of the contract.

Done in English in three originals, two originals being for the Contracting Authority and one original being for the Contractor.

For the Contractor

For the Contracting Authority

Name:

Name:

Position:

Position:

Signature:

Signature:

Date:

Date:

